



"Building Foundations, Paving Futures."



Emirates International Blocks & Interlock Factory

"Leading manufacturer of concrete blocks and interlock tiles, delivering quality and sustainable solutions for UAE construction projects."

Index

Colors 4

Paving Block

Rectengular Group 5

Rectengular Slabs 7

Uni Group 10

Square Group 12

Plaza Group 16

Octagonal Group 18

Concrete Blocks

Solid Blocks 20

Thermo Blocks 21

Hollow Blocks 22



COLORS

WWW.EBFUAE.COM

RECTENGLUAR

A classic and durable paving solution ideal for pathways, driveways, and high-traffic areas. Easy to install and maintain, it offers strength, stability, and a clean, timeless design.



TEXTURE
double mix
COMP-STRENGTH
49 N/mm²

SIZE

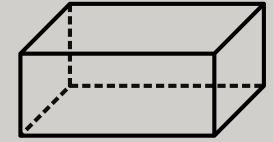

20 x 10 cm

THICKNESS
6cm / 60mm
WEIGHT
2.75kg

Collection



installation

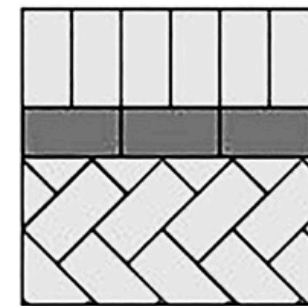

pencil line inlay

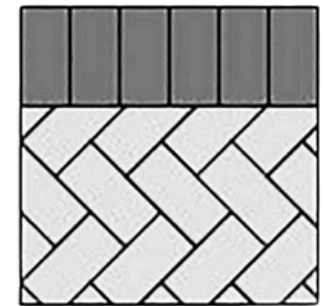

Soldier header

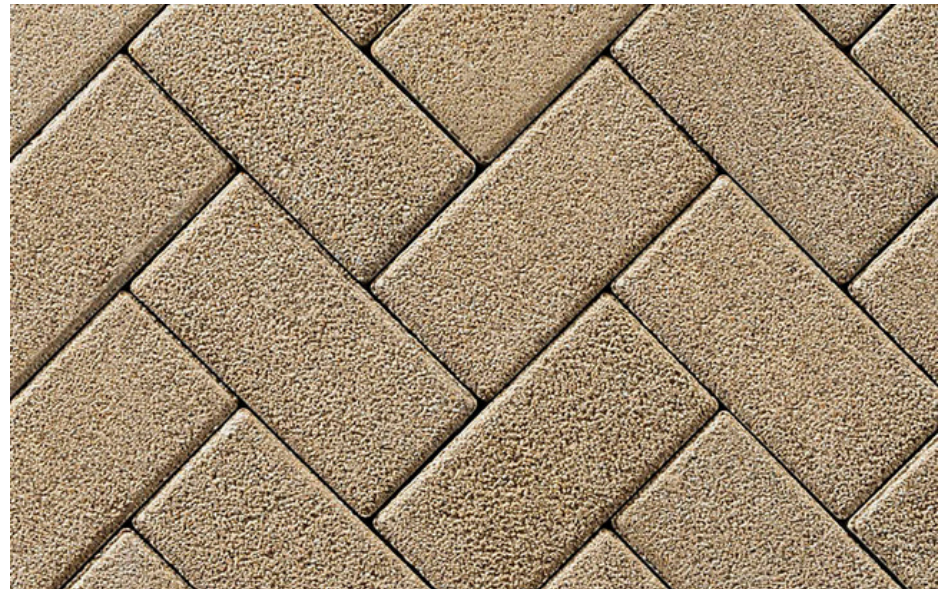
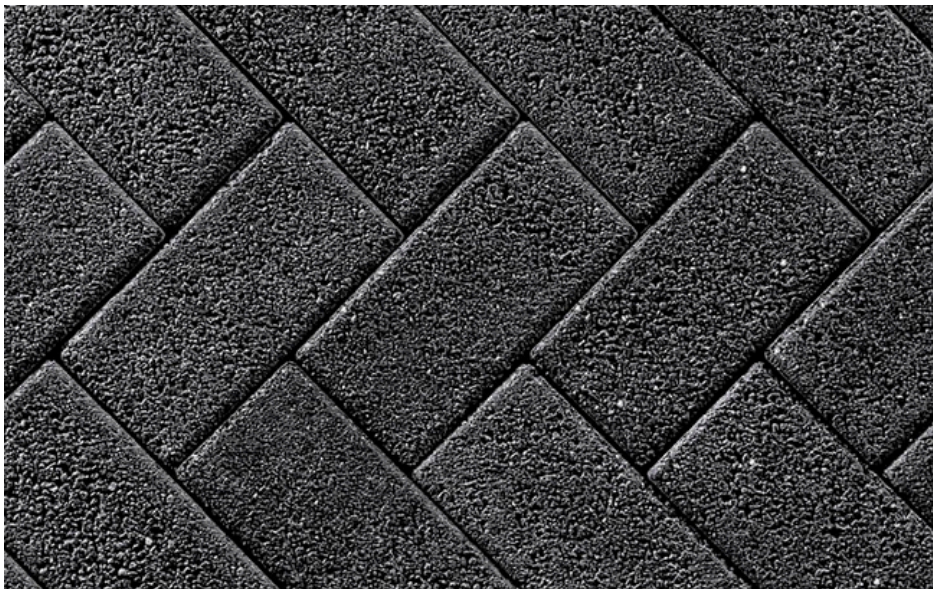

- 06_Pavers and slaps

RECTENGLUAR-SLAB

Rectangular slabs are durable, flat concrete tiles ideal for creating smooth surfaces in outdoor areas like patios, walkways, and garden spaces. They offer strength, stability, and a clean, modern look, making them a versatile choice for landscaping and construction projects.

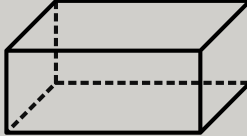

TEXTURE
double mix
COMP-STRENGTH
49 N/mm²

SIZE

40x80 CM

THICKNESS
8cm/80mm
WEIGHT
60KG

RECTENGLUAR-SLAB

Rectangular slabs are durable, flat concrete tiles ideal for creating smooth surfaces in outdoor areas like patios, walkways, and garden spaces. They offer strength, stability, and a clean, modern look, making them a versatile choice for landscaping and construction projects.

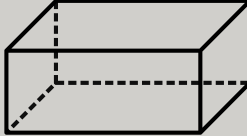
TEXTURE
double mix
COMP-STRENGTH
49 N/mm²

SIZE

30x60 CM
20X40 CM

THICKNESS
8cm/80mm
WEIGHT
60KG





- 09_Pavers and slaps

UNI-PAVER

Durable, interlocking tiles with a unique shape, ideal for high-traffic areas like driveways and parking lots. They offer strength, stability, and a polished look.

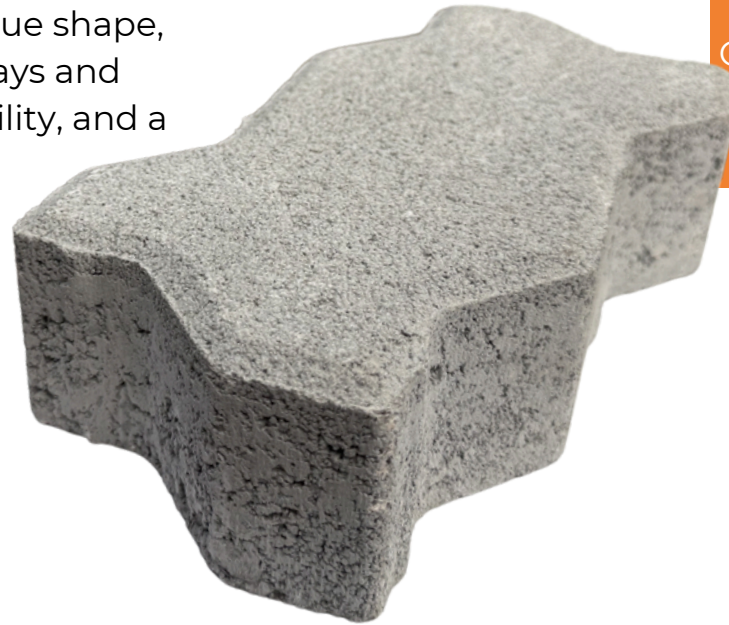

TEXTURE
double mix
COMP-STRENGTH
49 N/mm²

SIZE

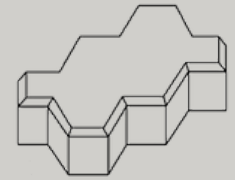

22.5x10.9 CM

THICKNESS
6cm / 60mm
8cm/80mm

WEIGHT
3.30KG
4.45KG

Collection



installation

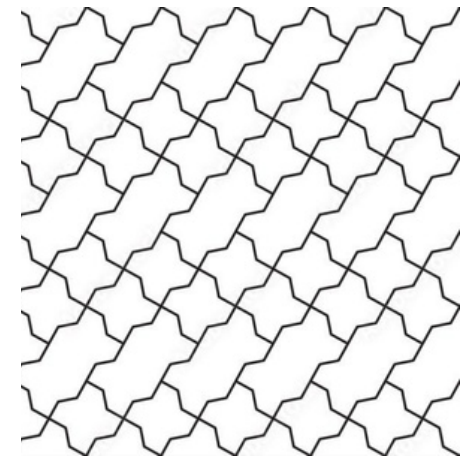

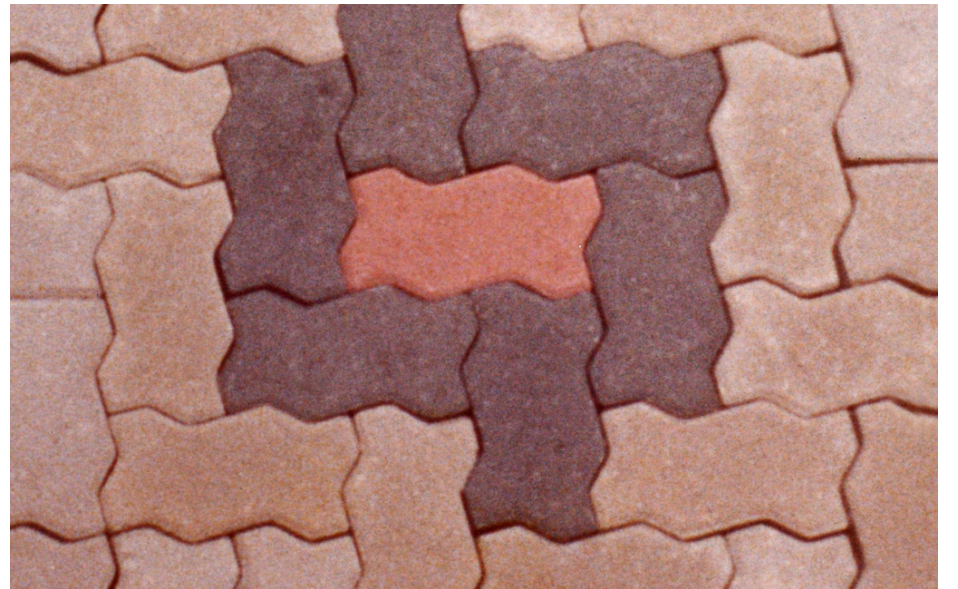
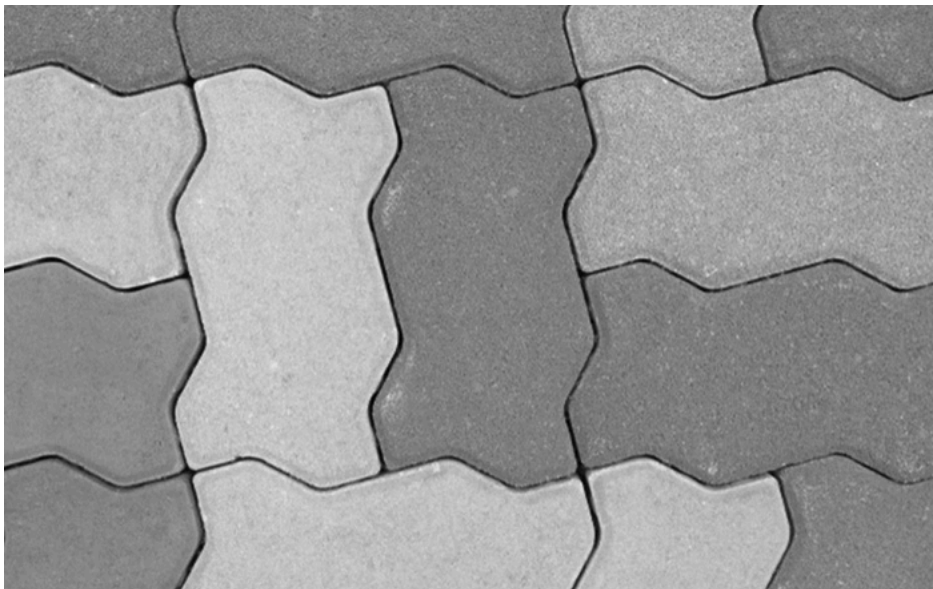
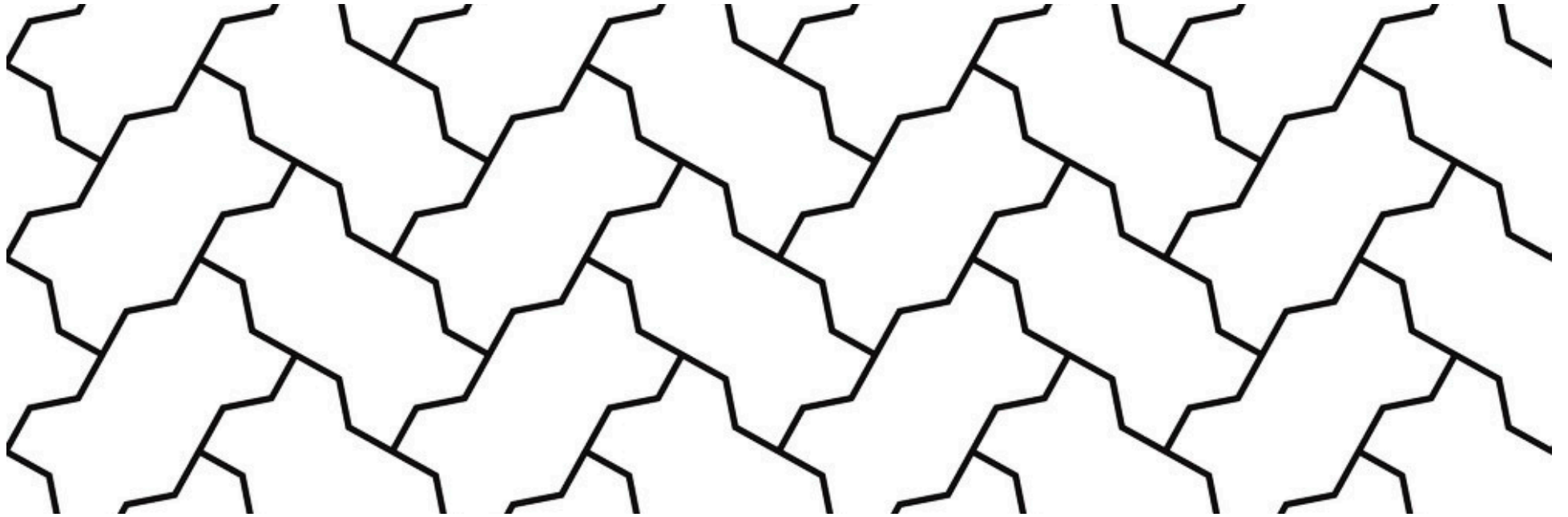

- 11_Pavers and slaps

SQUARES

Square interlock tiles are versatile and durable paving solutions ideal for pathways, patios, and open spaces. Their simple, geometric design offers flexibility in patterns while providing strength, stability, and a clean, modern look for outdoor areas.



TEXTURE
double mix
COMP-STRENGTH
49 N/mm²

SIZE

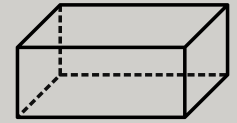

10x10 / 20x20cm
30x30 / 40x40cm

THICKNESS
6cm / 60mm

WEIGHT
1.40/5.65/12.70
21.50/22.50KG

Collection



installation

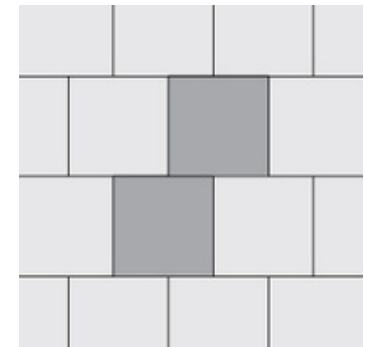

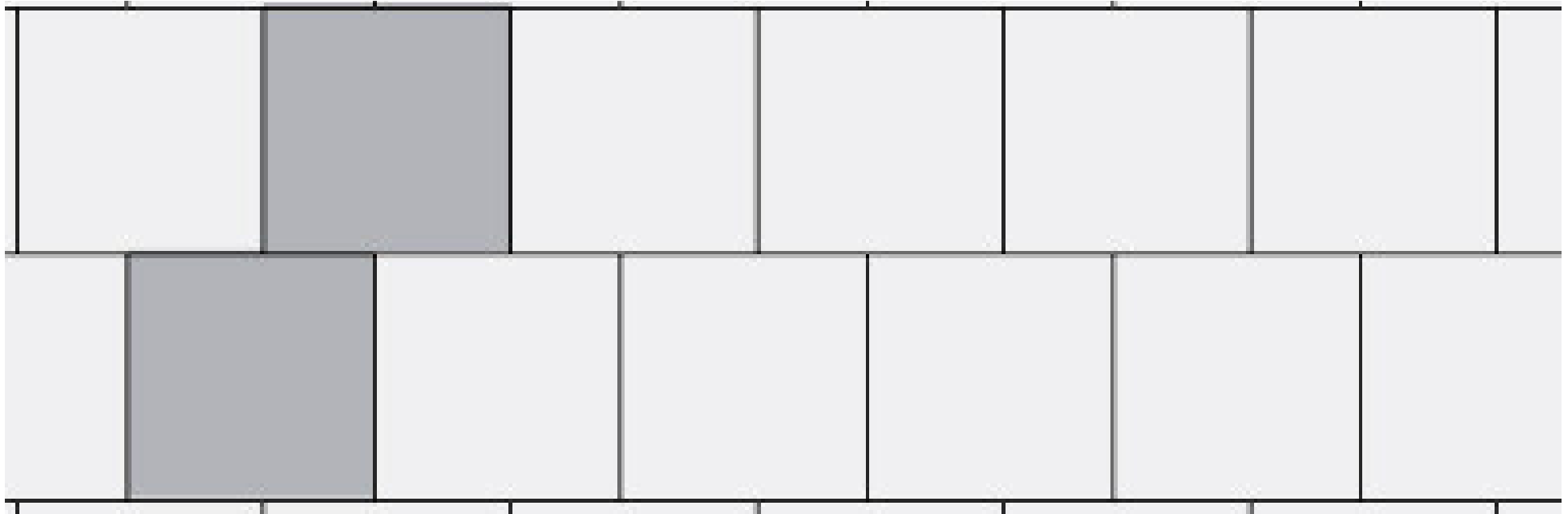

- 13_Pavers and slaps

SQUARES

Square pavers are versatile and durable tiles ideal for creating clean, symmetrical patterns in outdoor spaces. Perfect for patios, pathways, and courtyards, they offer a timeless design, easy installation, and the strength to withstand various weather conditions and traffic levels.



TEXTURE
double mix
COMP-STRENGTH
49 N/mm²

SIZE

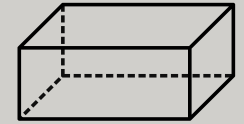

100x100mm

THICKNESS
6cm / 60mm

WEIGHT
1.40KG

installation

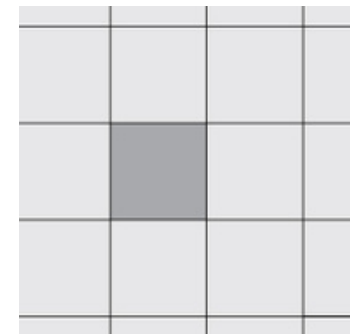

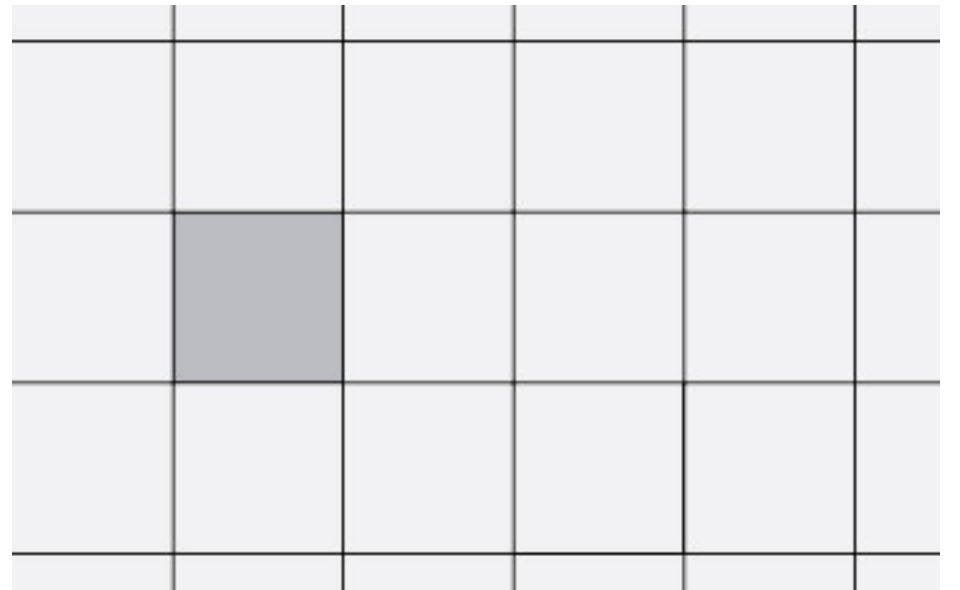
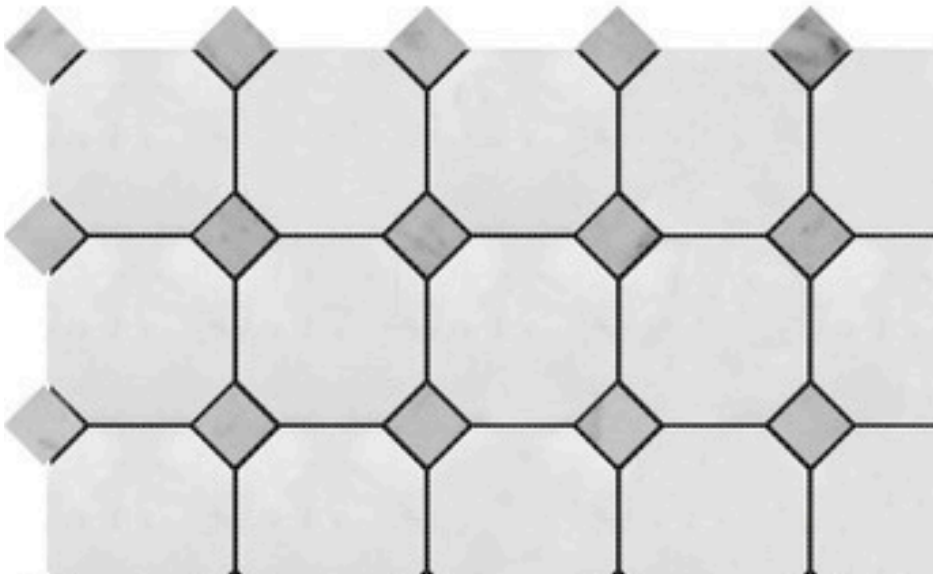

Add a little bit of body text

PLAZA

Plaza shape pavers are designed for large, open areas like courtyards, plazas, and walkways. Their smooth, elegant design ensures durability while providing a sophisticated and uniform look, perfect for creating expansive and aesthetically pleasing outdoor spaces.

TEXTURE
double mix
COMP-STRENGTH
49 N/mm²

SIZE

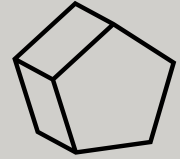

100x100x282mm

THICKNESS
6cm / 60mm
WEIGHT
6.30KG



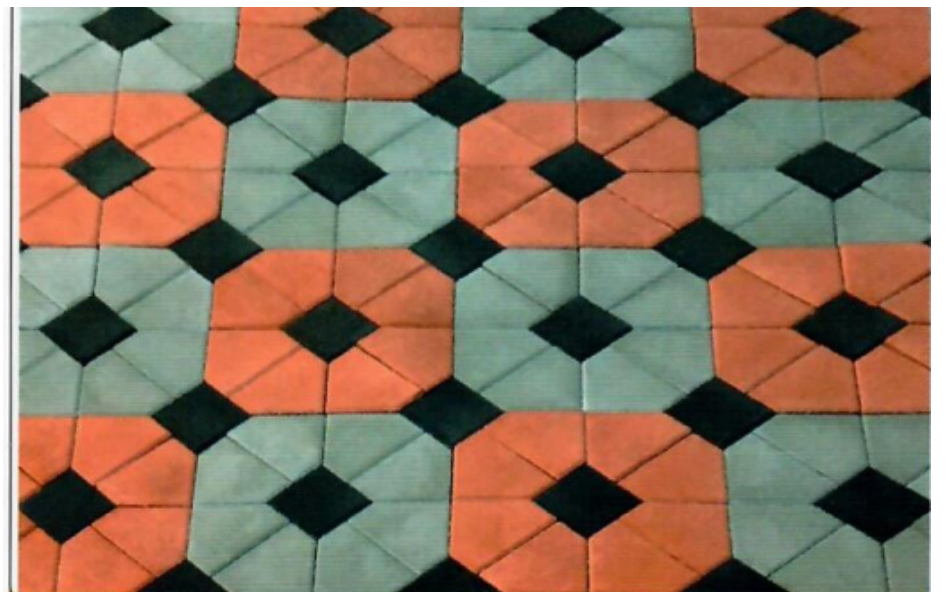
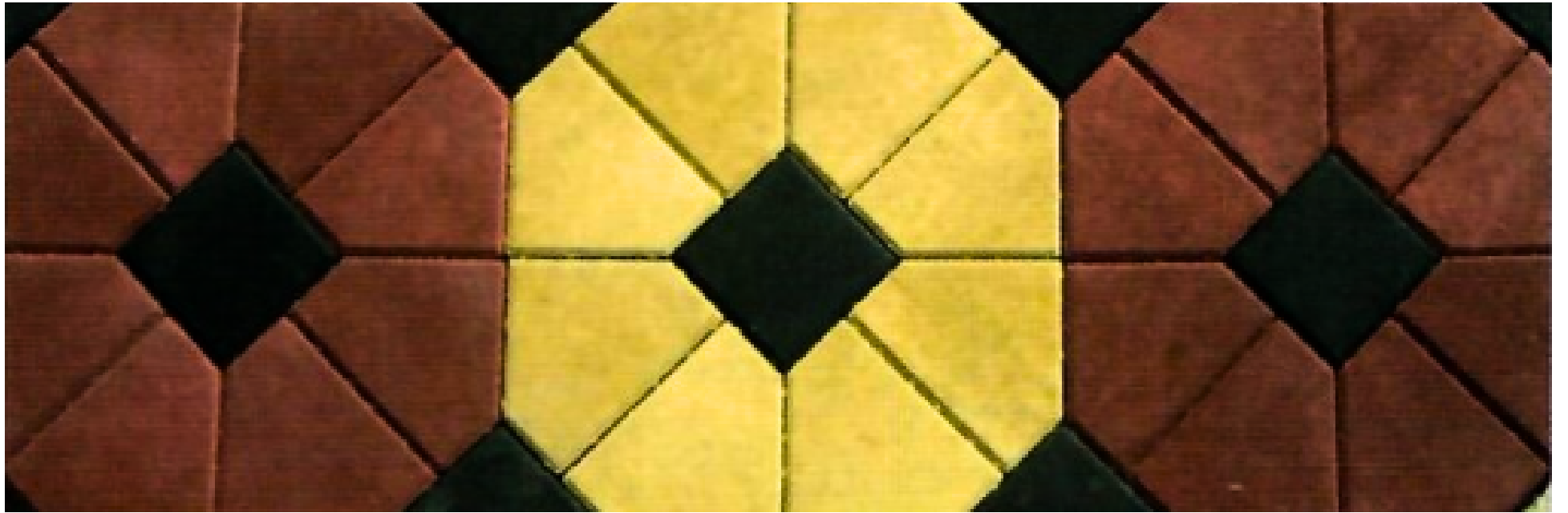

Add a little bit of body text

OCTAGON

Octagonal pavers feature a unique eight-sided design, perfect for adding a decorative touch to pathways, patios, and open spaces. Their distinctive shape allows for creative patterns, offering both durability and aesthetic appeal for outdoor areas.

TEXTURE

double mix

COMP-STRENGTH

49 N/mm²

SIZE

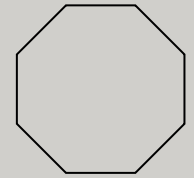

200x200mm

THICKNESS

6cm / 60mm

8cm/80mm

WEIGHT

4.5KG



installation





Add a little bit of body text

SOLIDS

3D MODEL

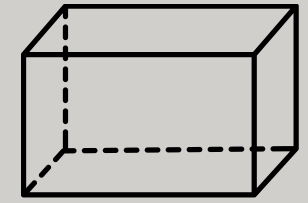

10-INCH Solid

Solid concrete blocks used for building foundations. They provide excellent strength and stability, ensuring a strong base for construction projects. Ideal for supporting heavy loads and ensuring structural integrity.

Collection



4-INCH SOLID



6-INCH SOLID



8-INCH SOLID

INSULATION BLOCKS

3D MODEL

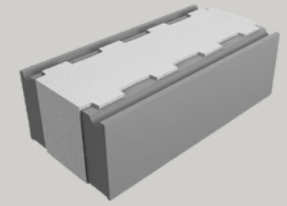

Insulation blocks are Lightweight blocks offering excellent thermal and sound insulation. Ideal for energy-efficient walls in residential and commercial buildings.

8-INCH insulation

Collection



**10-inch Insulation
110mm Foam**



**10-INCH INSULATION
60mm Foam**

Hollow-Blocks

3D MODEL

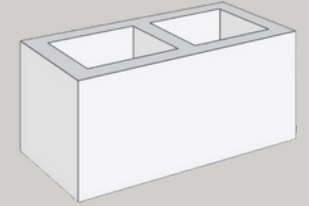

10-INCH Hollow

Lightweight and durable concrete blocks designed for efficient construction. Hollow blocks provide strength, insulation, and cost-effective solutions for walls and partitions in residential, commercial, and industrial projects.

Collection



4-INCH HOLLOW



6-INCH HOLLOW



8-INCH HOLLOW

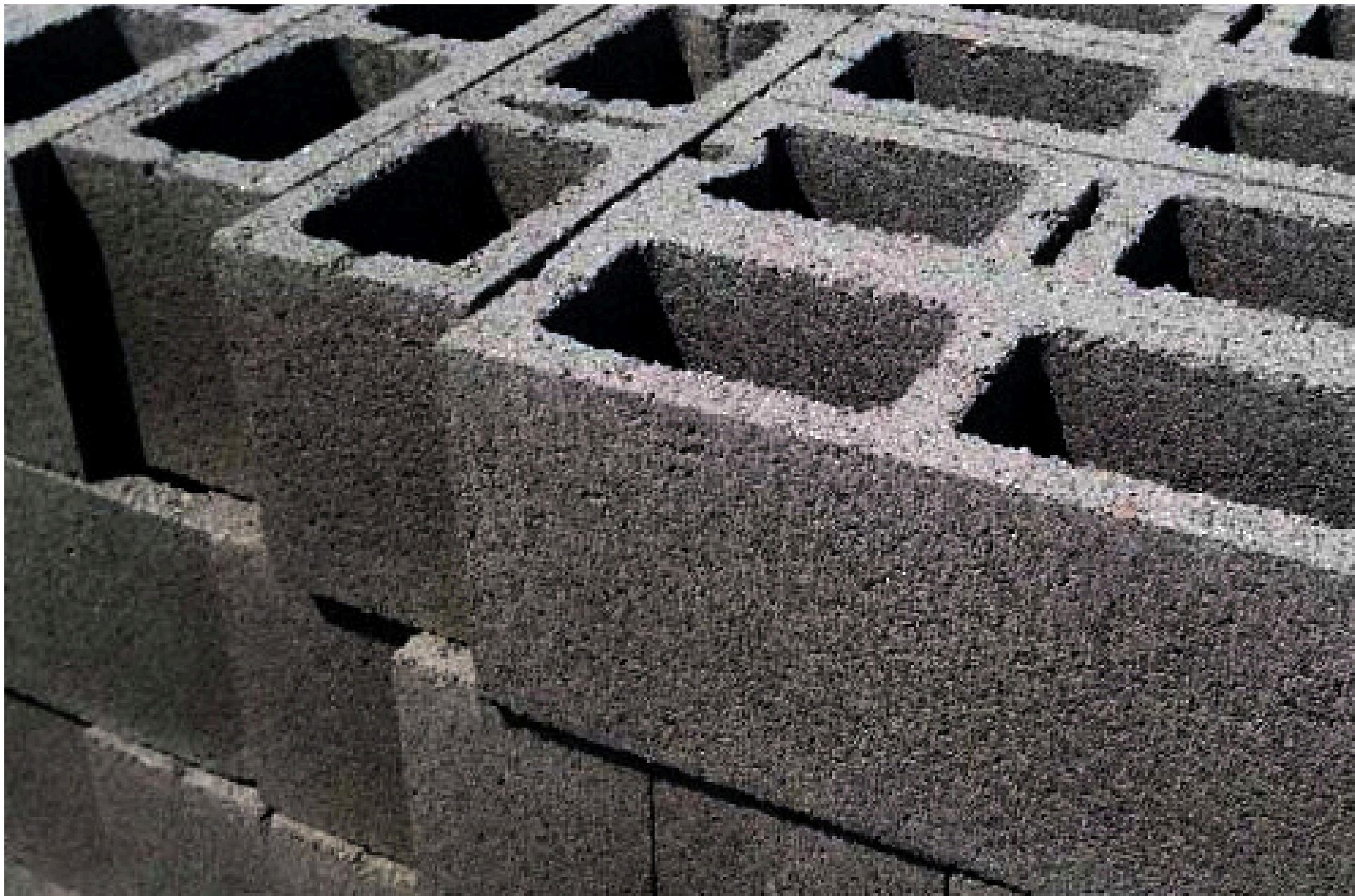

Add a little bit of body text